

SH Inox

Stainless steel shissor lift

Load capacity 1,0 t



TECHNICAL FEATURES

Load capacity 1,0 t
Forks mm 550x1.150

Entirely built in Aisi304 Stainless Steel, welded & polished in according with UNI EN 1672-1:2014, UNI EN 1672-2:2014, UNI EN ISO 14159:2008

Fully washable with water (IP66 protection)
Wheels & roller with stainless steel ball bearings

Nylon side axles to maximize stability

Manufacturer		Logimach
Model		SH Inox
Rated load capacity	Q (t)	1,0
Load centre	c (mm)	600
Wheight	kg	112
Tyres, drive end/load end (NY = Nylon)		NY/NY
Wheel size, drive end	mm	200x50
Wheel size, load end	mm	82x90
Fork dimensions	e/l (mm)	170/1.150
Overall fork width	b5 (mm)	550
Forks, min/max height	mm	88/820

FOCUS ON ITS ADVANTAGES

You can lift the load and operate at an ergonomic back height!

SH Inox is 100% "Made in Italy", the first quality synonymus, special for the food & pharmaceutical industry.

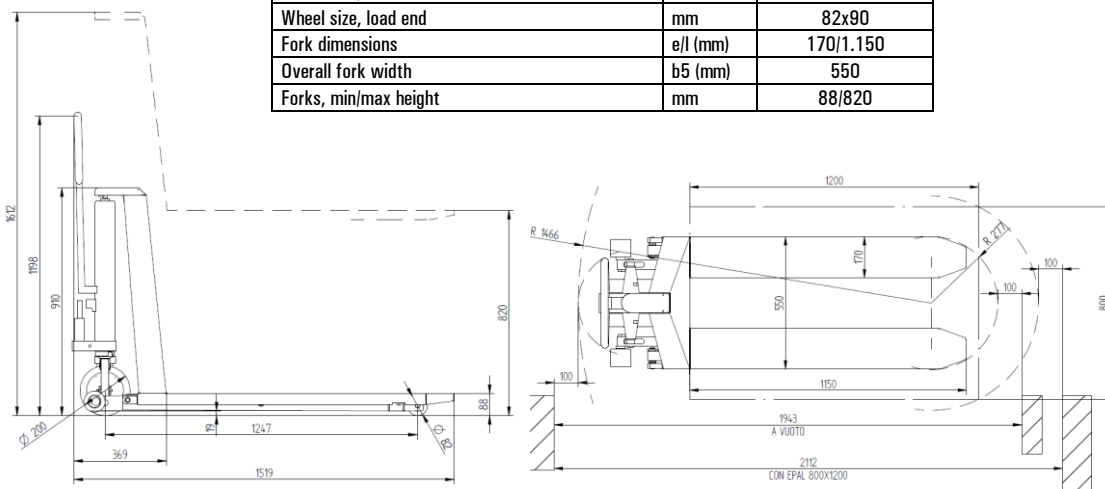

Lateral axles for maximum stability

CARRELLIFICIO CESENATE DI MINOTTI MARCO & C. SNC

Via Cerchia di Sant'Egidio, 850- 47521 Cesena (FC) - Italy
Tel. +39 0547 381150 - Fax +39 0547 631202
info@logimach.it www.logimach.com

Dealer