

PALLET TRUCKS

PALLET TRUCKS, STACKERS, BICI, OTHER



FORMULA UNO

IronWk

Carrellificio
Cesenate

OUR RANGE



Pag 4



Pag 5



Pag 5



Pag 6



Pag 7



Pag 7



Pag 9



Pag 9



Pag 10



Pag 10



Pag 11



Pag 13



Pag 14



Pag 16



Pag 15



Pag 17



HIGH LIFT



CEET 20

ELECTRIC STACKER



Load capacity kg 2.000
Lifting height up to mm 3.200
24V 240 Ah battery



Load capacity kg 1.500
Lifting height up to mm 5.000
Battery up to 240Ah

CEET 15

ELECTRIC STACKER

CEET 12

ELECTRIC STACKER



Load capacity kg 1.200
Lifting height up to mm 5.000
24V 160Ah battery



Load capacity kg 250
Lifting height mm 1.500
24V 160 Ah battery

JOLLY CNT

COUNTERBALANCED STACKER

CEET DA 15

DOUBLE STACKER



Load capacity kg 1.500
Lifting height up to mm 3.200 + 190 mm
Battery up to 240 Ah



Load capacity kg 1.200
Lifting height up to mm 3.200 + 190 mm
24V 160 Ah battery

CEET DA 12

DOUBLE STACKER

CMB

ELECTRIC STACKER



Load capacity kg 500
Lifting height up to mm 2.000
2x12V 80Ah AGM battery
Tailor-made version available

CEM model

Load capacity kg 800
Lifting height mm 1.600 or mm 1.100



CEE model

Load capacity kg 1.000
Lifting height up to mm 3.200
12V battery



STACKERS

STACKERS

LOW LIFT



JIANT

ELECTRIC PALET TRUCK WITH PLATFORM



**SPECIAL FOR FRUIT
AND VEGETABLES**

Cushioned operator platform
Electric steering – Max speed 12 km/h
375Ah battery – Load capacity kg 2.000



**SPECIAL FOR FRUIT
AND VEGETABLES**

Cushioned operator platform
Max speed 8,5 km/h
Battery up to 270Ah – Load capacity kg 2.000

JOKER GT

ELECTRIC PALET TRUCK WITH PLATFORM

JOLLY GT

ELECTRIC PALLET TRUCK



Load capacity kg 2.000 – 240Ah battery
Great autonomy



**SPECIAL FOR FRUIT
AND VEGETABLES**

Load capacity 1.600 / 2.000 kg – 160Ah battery
Sturdy and compact size

JOLLY

ELECTRIC PALLET TRUCK

FOR FRUIT AND VEGETABLE

FORKS FOR ELECTRIC PALLET TRUCK

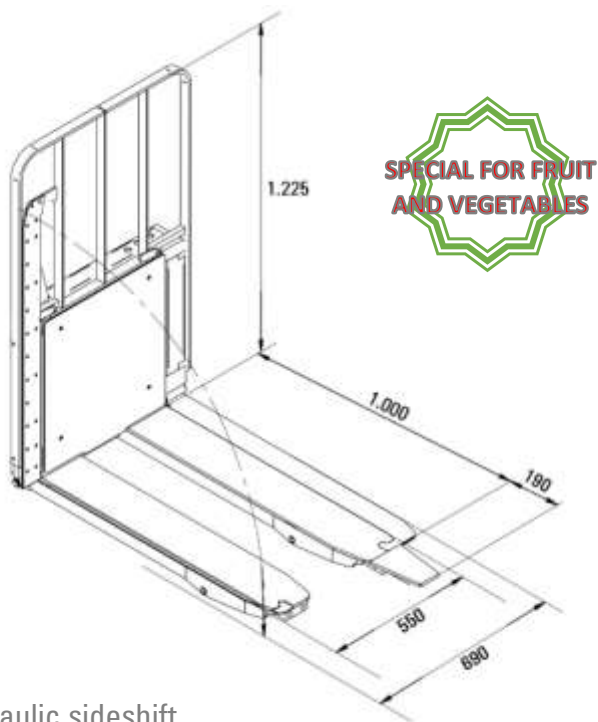

Hydraulic sideshift
Widenings for forks
Fork extensions
Load backrest



Load capacity 4.000 / 5.000 Kg
345Ah battery
Frame with thick sheets

TE HD

ELECTRIC PALLET TRUCK – HIGH LOAD CAPACITY

BICI, HAND PALLET TRUCKS, OTHER



BICI

TROLLEY WITH THREE WHEELS

FORMULA UNO



SPECIAL FOR FRUIT AND VEGETABLES

Ruote Formula UNO, in gomma superelastica
Portata kg 250
Prolunga estensibile

Bici



Bici with grid



Bici



SPECIALE PER ORTOFRUTTA

Ruote Formula UNO, in gomma superelastica
Portata kg 250
Prolunga estensibile

FORMULA UNO

BICI

TROLLEY WITH THREE WHEELS

CG8 / 4R-007

VARIOUS TROLLEYS



CG8 F1

CG8 PN



CG8 PN

CG8 F1



4R-007

Folding handle
Extendable extension
Load capacity kg 200



BICI IN FRUIT AND VEGETABLES MARKET

P20 - P30

HAND PALLET TRUCKS



Load capacity 2.000 / 3.000 kg
Forks mm 560x1.150
Tailor-made execution



Load capacity kg 5.000
Forks mm 580x1.150
Tailor-made execution

P50

HIGH CAPACITY HAND PALLET TRUCK

B100

WINCH MANUAL LIFTER



Load capacity kg 100
Lifting stroke mm 975
Sheet metal top 50x50 cm
Tailor-made execution



Load capacity up to kg 300
Lifting stroke mm 1.375
Sheet metal top 50x50 cm or coil clamp
Tailor-made execution

B300

WINCH MANUAL LIFTER

PALLET TRUCKS

IMPORT PALLET TRUCKS

Hand pallet truck
Load capacity kg 2.500



Hand shissor lift
Load capacity kg 1.000
Lifting height mm 800



Elevatore manuale
SFH1600
Portata kg 1.000

Electric pallet truck
Load capacity kg 1.500
Forks 540x1.150



Electric stacker
Load capacity kg 1.000
Lifting height up to mm 3.500

Semi-electric stacker
Load capacity kg 1.000
Lifting height mm 1.600



STACKERS

IMPORT PALLET TRUCKS

OUR SERVICES



- ✓ Consulting, design and manufacturing of **customized pallet truck to the specific customer's need**
- ✓ Large warehouse of spare parts ready for delivery

We have a network of authorized dealers and technicians throughout Italy and Europe to ensure that the machine are always efficient and in an excellent state of maintenance.

Innovative ideas & solutions
for your needs



FORMULA UNO

ironWk

Carrellificio
Cesenate